

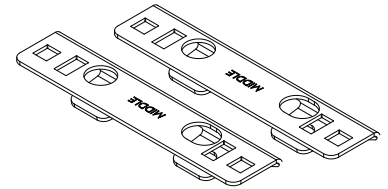

'Tradie Tuff' COMMERCIAL ROOF RACKS

TOYOTA HIACE SLWB, 05/2019 - ON

FIXED MOUNT



PART NUMBER: VAS.RC1006, VAS.RA1006, VAS.RC1112, VAS.RA1112, VAS.RC1113, VAS.RA1113.

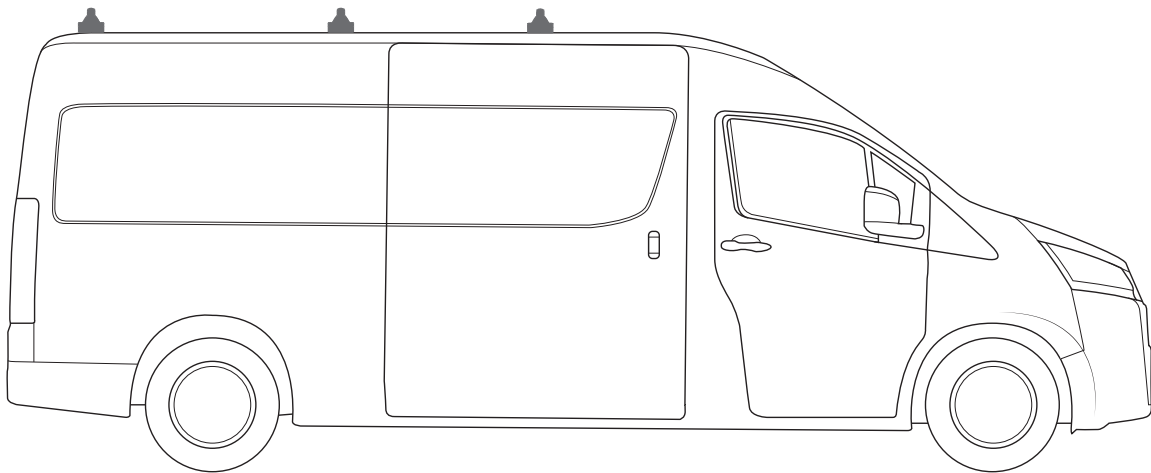

Note:

- PLEASE READ INSTRUCTIONS AND CHECK CONTENT PRIOR TO INSTALLING.
- PLACE INSTRUCTIONS IN VEHICLES GLOVE COMPARTMENT AFTER INSTALLING.



3 Bar maximum capacity: 120kg

Tested to AS/NZS 1235-200 ADR standards

- Please check your vehicle's manual for vehicle load capacity (please do not exceed the lowest load rating) and please download and read our Load Rating guide which can be found on our website vas.com.au.
- Load rating is based on driving on sealed roads to road conditions and includes weight of roof rack system.

Important information

- Complete maintenance checks weekly including bolt connections and tightness.
- Heavy loads carried near feet
- Overhanging loads should conform to relevant state laws
- Check tie down strap tension every 50klm as loads can shift
- Specialised equipment carriers such as ladder slides should be used
- Ensure your roof racks, ladder rails and or load does not inhibit the tailgate lifting on vehicles manufactured with these doors
- Check car park heights before entering
- Keep load under the maximum capacity
- Use non stretch fastening straps
- Remove roof racks prior to using an automatic car wash

Note: The handling characteristics of a vehicle will change when a carrier system is fitted. Driving technique such as speed reduction, cornering techniques and braking distances should be altered to allow for these changes.

Kit Inclusions

Item	Part	3 Bar
1	M6 x 30mm Button Head Screw - F008	12
2	M6 Spring Washer - F012	12
3	M6 x 16mm Flat Washer - F011	12
4a	M8 x 25mm Cap Screw - F048	12
4b	M8 Spring Washer - F018	12
5	M8 x 17mm Washer - F011	12
6	Middle Common Bracket - C144	6
7	4mm Allen Tool - C028	1

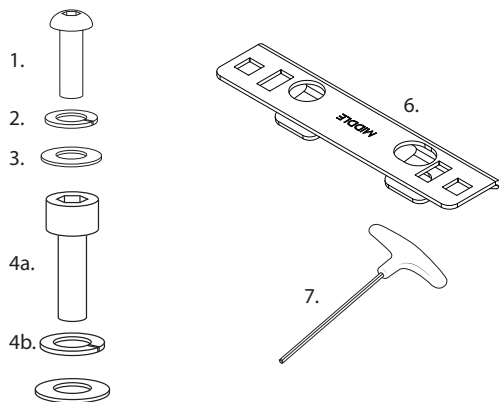

Tools Required

- 1 - 10mm Socket Wrench.
- 2 - 4mm Allen Key (provided).
- 3 - 6mm Allen Key.
- 4 - 17mm Spanner.
- 5 - Butyl Mastic.

Required kits (as separate):

- Crossbar x3 1650mm
- 10mm Spacer x 2
- Crossbar Mount Kit x 3

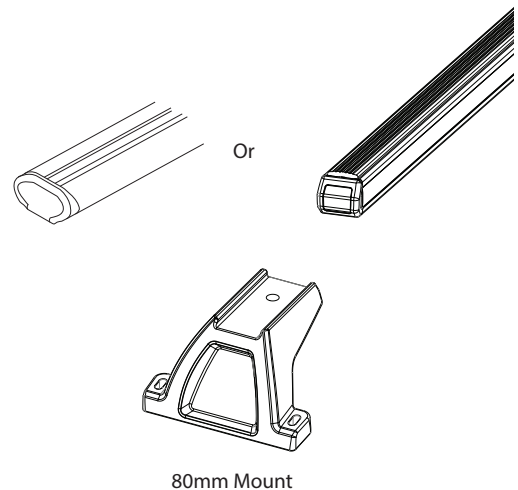

Step 2

Remove the factory mounts from your roof. Apply butyl mastic in and around the holes in the roof to ensure your roof remains water tight.

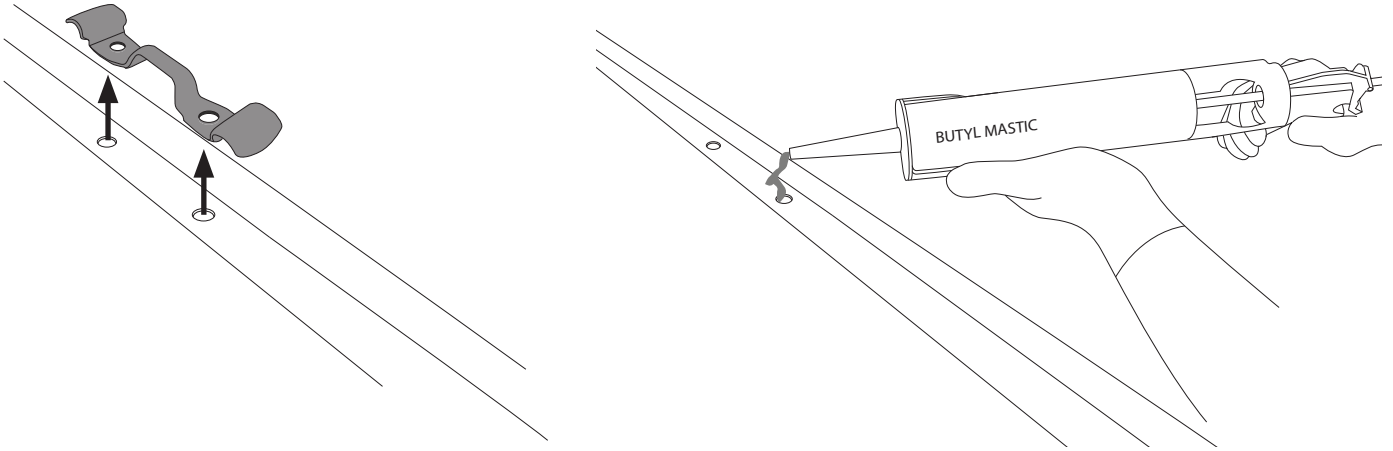

Step 1

Identify the factory mounts on the roof of the vehicle. Using a 10mm socket wrench undo the mounts. You must alternate loosening the bolts progressively to ensure mounts are not dislodged on the inside of the vehicle.

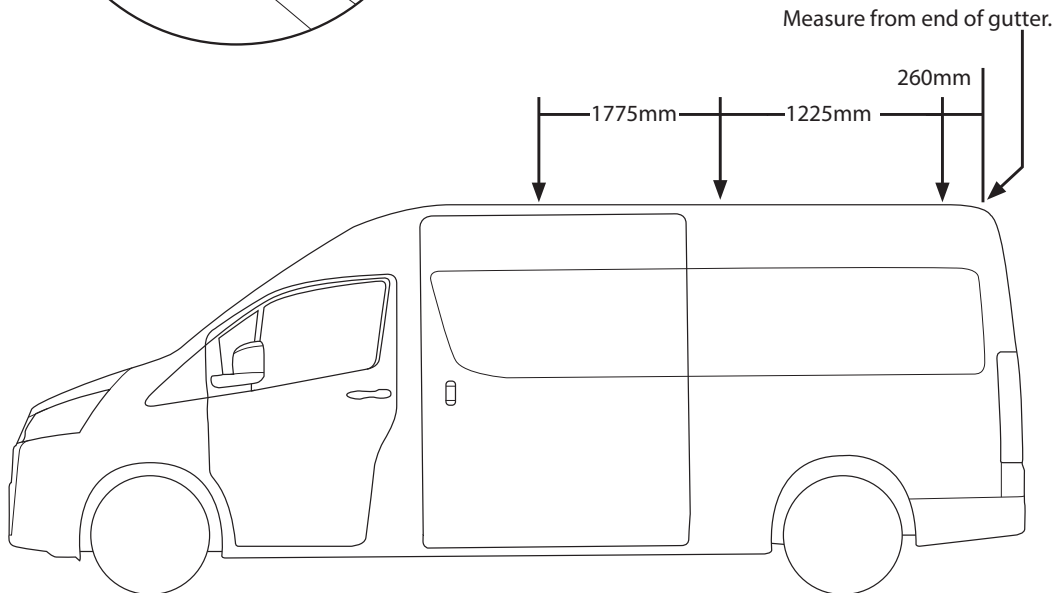
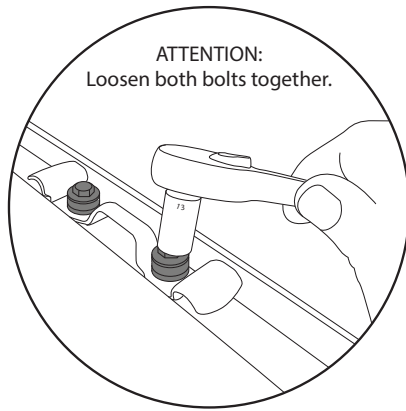

Step 3

1 - Install the M8 hardware into each bracket. 2 - Place the brackets into position onto the mounting points of your roof. The arrows on the front and rear brackets face the front of your vehicle. 3 - Tighten the brackets in place with an allen key.

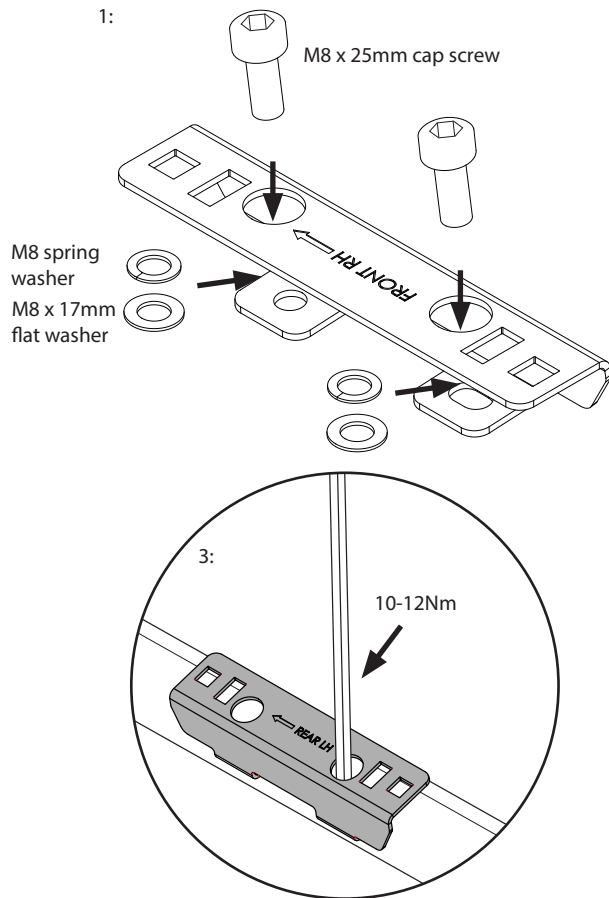

2:

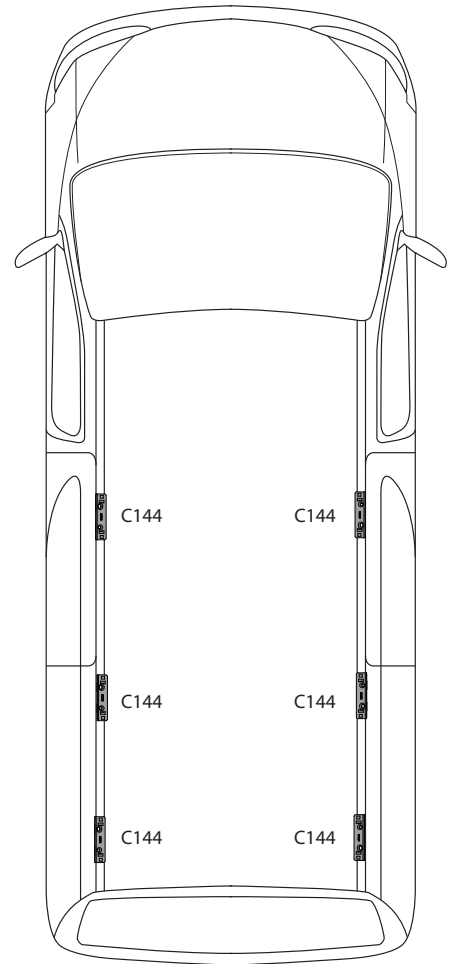

Step 4

Complete crossbar mount kits as specified in their instructions. Place the crossbars onto the installed brackets in the roof. Fix in place with the M6 hardware provided and tighten with an allen key.

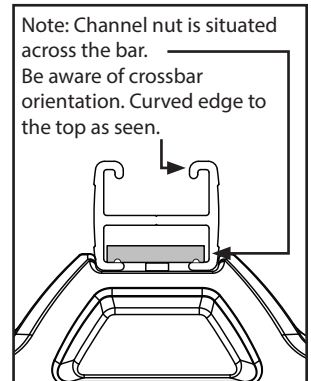
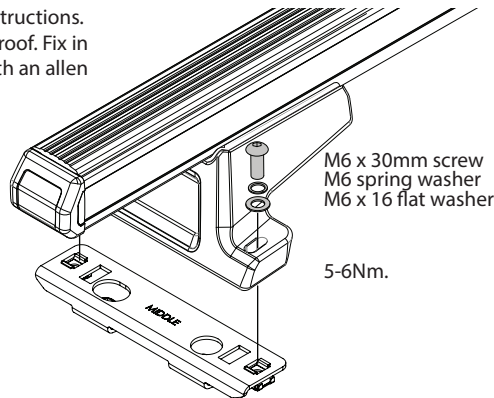

NOTE

ATTENTION:
Kit for standard legs only.
Thoroughly check all fasteners are secure before driving away.
Front crossbar mount require 10mm spacer.

