

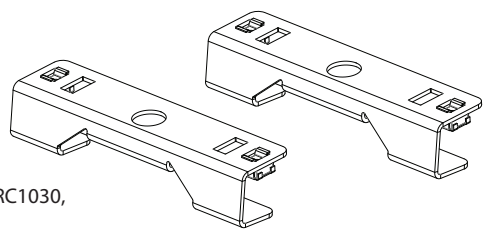

'Tradie Tuff' COMMERCIAL ROOF RACKS

PEUGEOT EXPERT, 2013 - ON

FIXED MOUNT



PART NUMBER: VAS.RC1066, VAS.RA1066, VAS.RC1055, VAS.RA1055, VAS.RC1029, VAS.RA1029, VAS.RC1030, VAS.RC1023, VAS.RA1023, VAS.RC1025, VAS.RA1025.

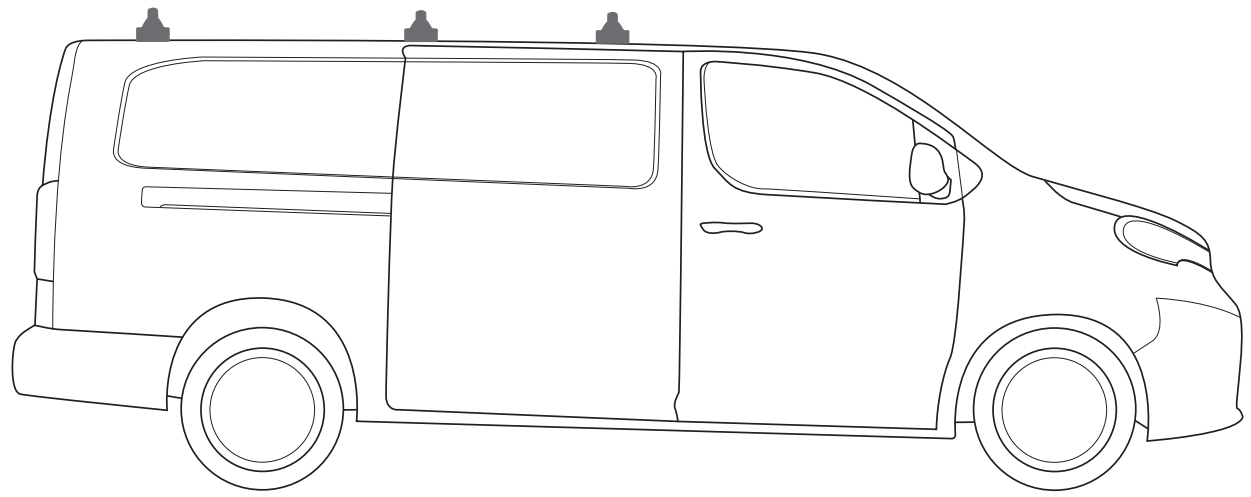

Note:
- PLEASE READ INSTRUCTIONS AND CHECK CONTENT PRIOR TO INSTALLING.
- PLACE INSTRUCTIONS IN VEHICLES GLOVE COMPARTMENT AFTER INSTALLING.



3 Bar maximum capacity: 100kg
Tested to AS/NZS 1235-200 ADR standards

- Please check your vehicle's manual for vehicle load capacity (please do not exceed the lowest load rating) and please download and read our Load Rating guide which can be found on our website vas.com.au.
- Load rating is based on driving on sealed roads to road conditions and includes weight of roof rack system.

Important information

- Complete maintenance checks weekly including bolt connections and tightness.
- Heavy loads carried near feet
- Overhanging loads should conform to relevant state laws
- Check tie down strap tension every 50klm as loads can shift
- Specialised equipment carriers such as ladder slides should be used
- Ensure your roof racks, ladder rails and or load does not inhibit the tailgate lifting on vehicles manufactured with these doors
- Check car park heights before entering
- Keep load under the maximum capacity
- Use non stretch fastening straps
- Remove roof racks prior to using an automatic car wash

Note: The handling characteristics of a vehicle will change when a carrier system is fitted. Driving technique such as speed reduction, cornering techniques and braking distances should be altered to allow for these changes.

Kit Inclusions

Item	Part	3 Bar
1	M6 x 30mm Button Head Screw - F008	12
2	M6 Spring Washer - F012	12
3	M6 x 16mm Flat Washer - F011	12
4	M8 x 16mm Button Head Screw - F016	6
5	M8 x 16mm Flat Washer - F017	6
6	M8 Nyloc Nut - F021	6
7	Common Bracket - C161	6
8	4mm Allen Tool - C028	1

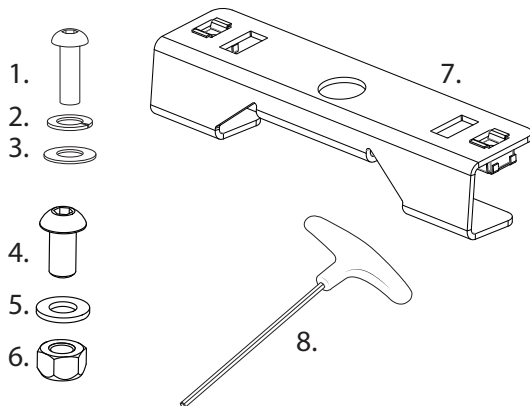

Tools Required

- 1 - 13mm Wrench.
- 2 - 4mm Allen Key (provided).
- 3 - 5mm Allen Key.

Required kits (as separate):

- Crossbar x 3 1500mm
- 10mm Spacer x 2
- Crossbar Mount Kit x 3

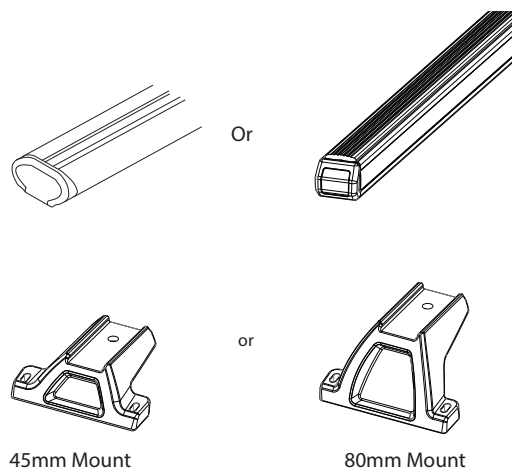

Step 1

Identify the factory mounts on the roof of the vehicle. Slide a nyloc nut under each mount, with the nut facing downward.

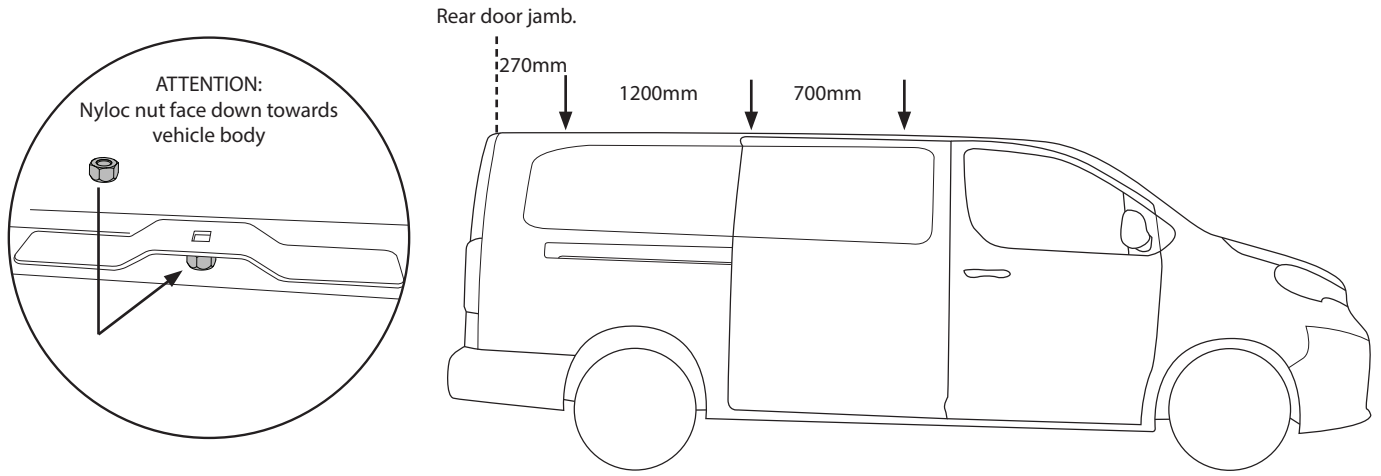

Step 2

Assemble the M8 hardware into the brackets. Place the bracket assemblies over the mounts on the roof with nyloc nuts beneath.

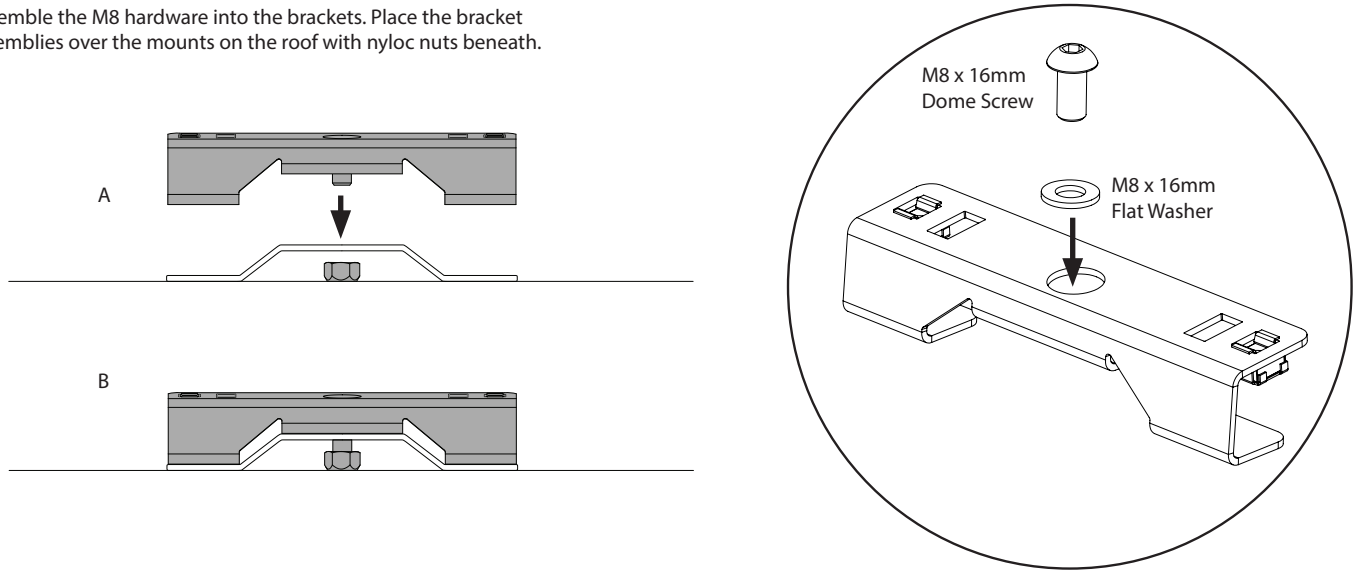

Step 3

1 - Using the 5mm allen key, tighten the M8 dome screw. The nyloc nut will need to be gripped with a 13mm wrench to prevent it from spinning during tightening.

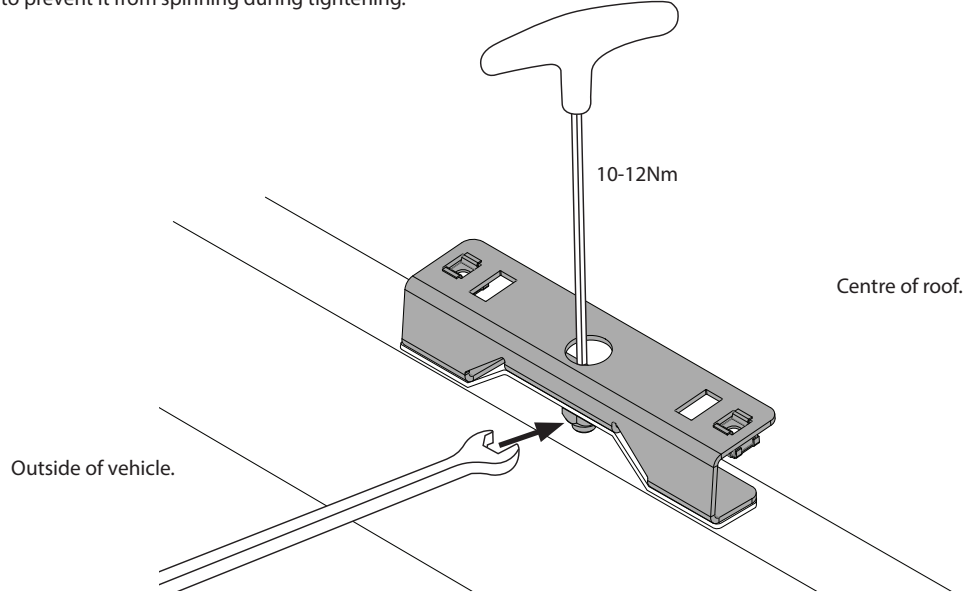

Step 4

Complete crossbar mount kits as specified in their instructions. Place the crossbars onto the installed brackets in the roof. Fix in place with the M6 hardware provided and tighten with an allen key. **The rear crossbar will require a 10mm spacer.**

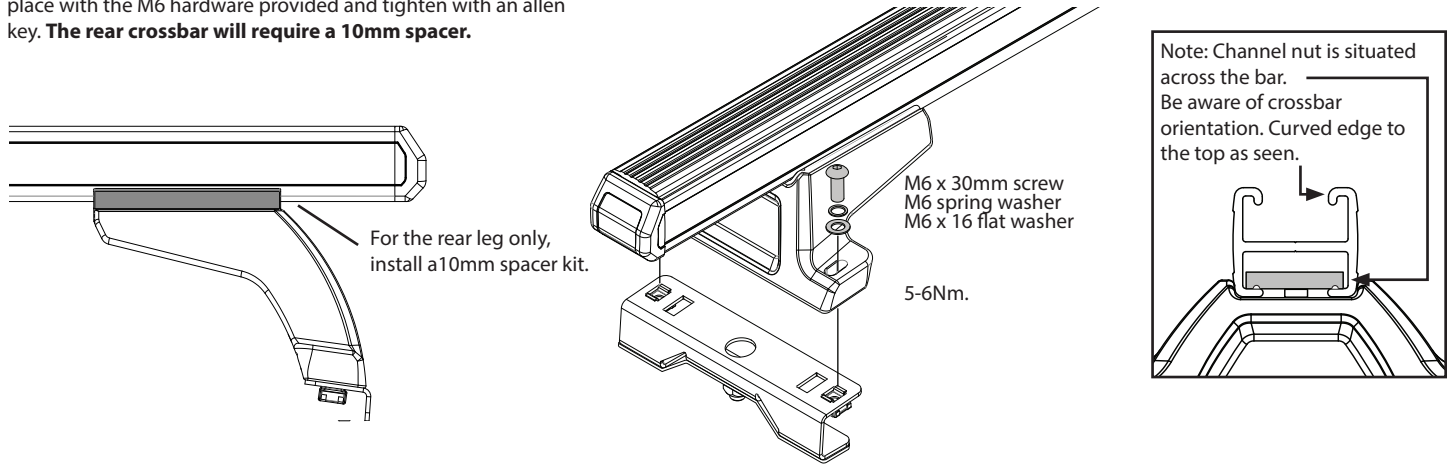

NOTE

ATTENTION:

Thoroughly check all fasteners are secure before driving away. Heights are for standard unloaded vehicles. Always check your specific vehicles height.

