

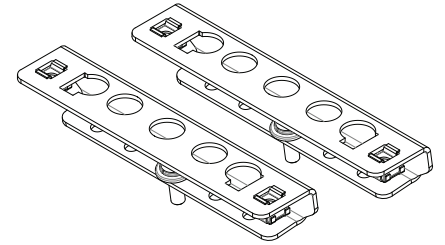

'Tradie Tuff' COMMERCIAL ROOF RACKS

MITSUBISHI EXPRESS X82 VAN,
SWB & LWB 2020 - ON

FIXED MOUNT



PART NUMBER: VAS.RC1096, VAS.RA1096, VAS.RC1038, VAS.RA1038, VAS.RC1117, VAS.RA1117, VAS.RC1036, VAS.RC1227, VAS.RA1227, VAS.RC1053, VAS.RA1053, VAS.RC1225, VAS.RA1225, VAS.RC1057, VAS.RA1057.

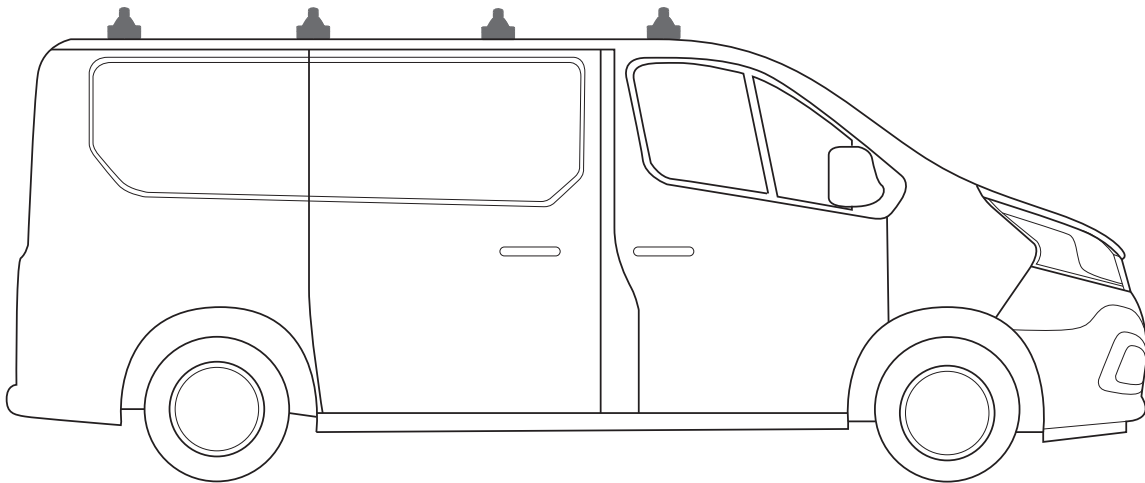

Note:

- PLEASE READ INSTRUCTIONS AND CHECK CONTENT PRIOR TO INSTALLING.
- PLACE INSTRUCTIONS IN VEHICLES GLOVE COMPARTMENT AFTER INSTALLING.



3 Bar maximum capacity: 100kg

Tested to AS/NZS 1235-200 ADR standards

- Please check your vehicle's manual for vehicle load capacity (please do not exceed the lowest load rating) and please download and read our Load Rating guide which can be found on our website vas.com.au.
- Load rating is based on driving on sealed roads to road conditions and includes weight of roof rack system.

Important information

- Complete maintenance checks weekly including bolt connections and tightness.
- Heavy loads carried near feet
- Overhanging loads should conform to relevant state laws
- Check tie down strap tension every 50klm as loads can shift
- Specialised equipment carriers such as ladder slides should be used
- Ensure your roof racks, ladder rails and or load does not inhibit the tailgate lifting on vehicles manufactured with these doors
- Check car park heights before entering
- Keep load under the maximum capacity
- Use non stretch fastening straps
- Remove roof racks prior to using an automatic car wash

Note: The handling characteristics of a vehicle will change when a carrier system is fitted. Driving technique such as speed reduction, cornering techniques and braking distances should be altered to allow for these changes.

Kit Inclusions

Item	Part	3 Bar	4 Bar
1	M6 x 30mm Button Head Screw - F008	12	16
2	M6 Spring Washer - F012	18	24
3	M6 x 16mm Flat Washer - F011	18	24
4	M6 x 20mm Button Head Screw - F006	6	8
5	Common Bracket - C087	6	8
6	4mm Allen Tool - C028	1	1

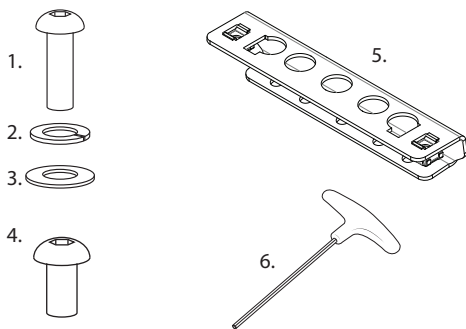

Tools Required

- 1 - 21mm Socket Wrench.
- 2 - 4mm Allen Key (provided).
- 3 - 10mm Spanner.
- 4 - Butyl Mastic.
- 5 - 4mm Allen Tool (provided).

Required kits (as separate):

- Crossbar x 3 or 4 1650mm
- Crossbar Mount Kit x 3 or 4

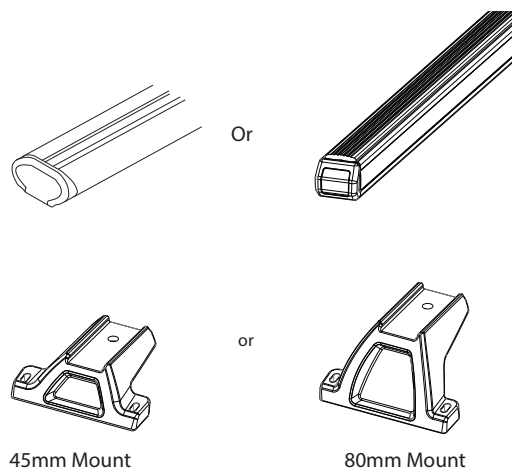

Step 1

Identify the factory mounts on the roof of the vehicle. Using a 21mm socket wrench undo the mounts. These positions can be used as a guide.

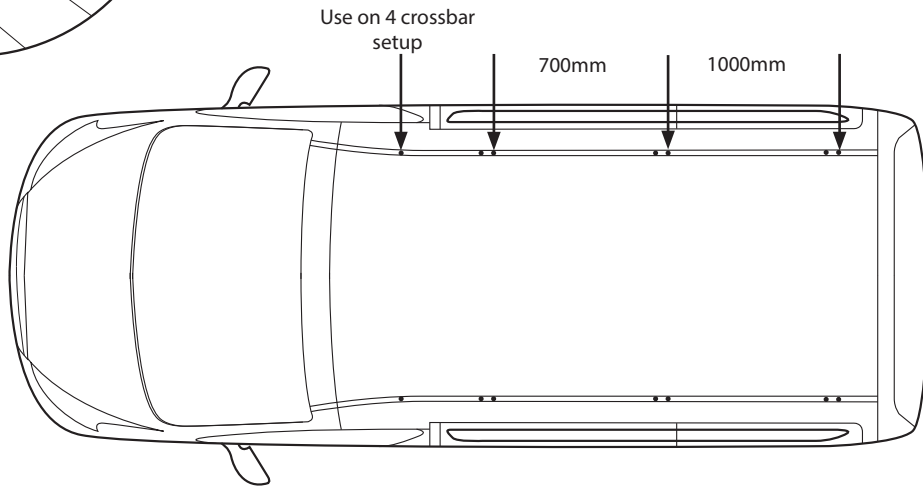
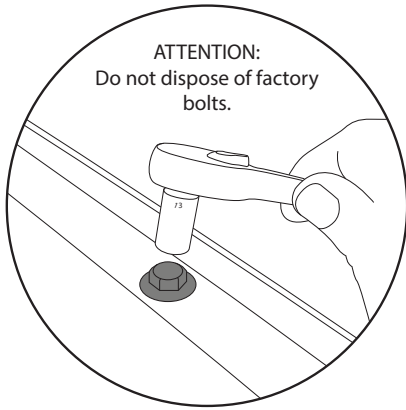

Step 2

Remove the factory mounts from your roof. Apply butyl mastic in and around the holes in the roof to ensure your roof remains water tight.

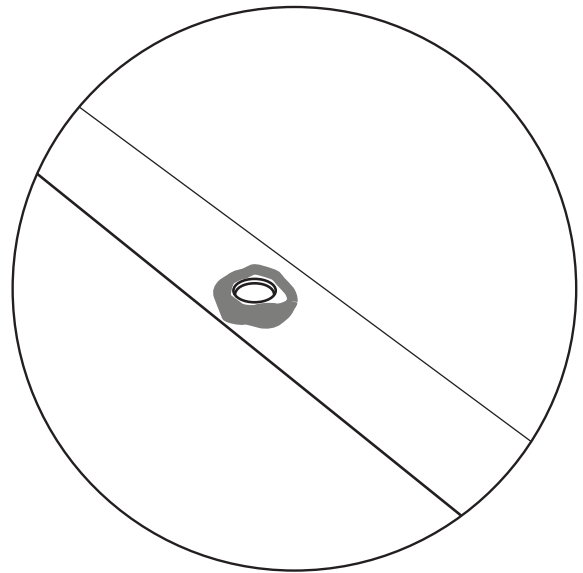
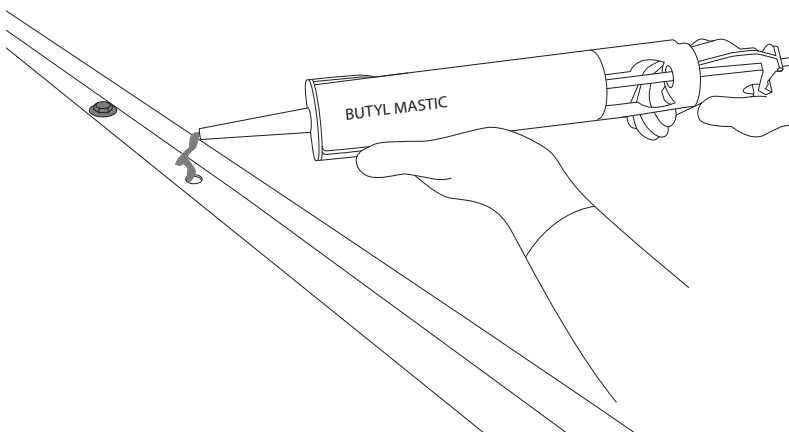

Step 3

1 - Install the M6 hardware into each bracket. 2 - Place the brackets into position onto the mounting points of your roof. 3 - Tighten the brackets in place with the allen key provided.

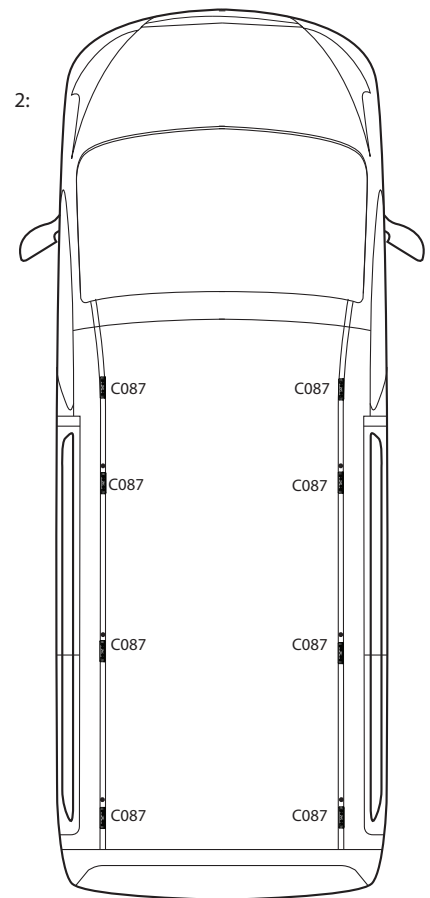
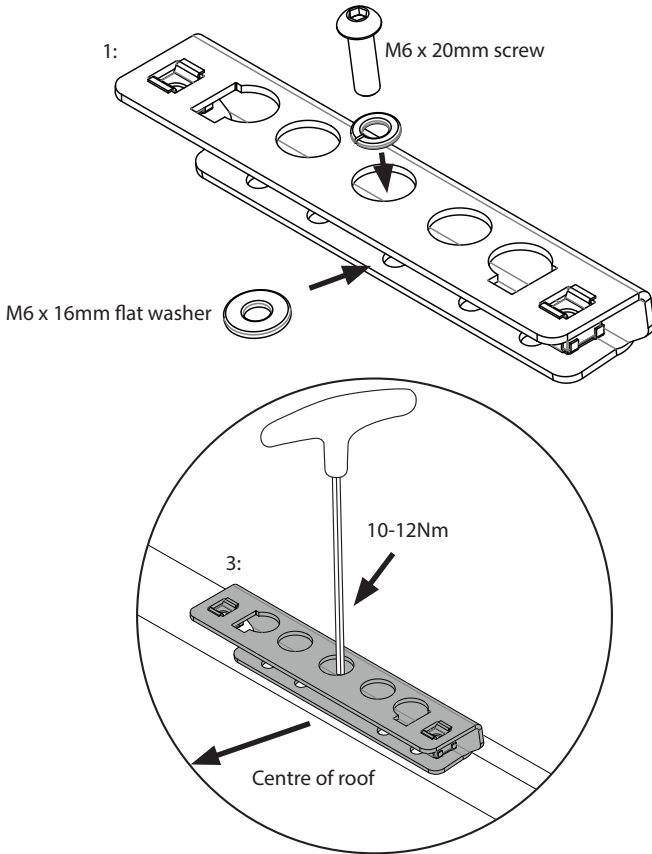

Step 4

Complete crossbar mount kits as specified in their instructions. Place the crossbars onto the installed brackets in the roof. Fix in place with the M6 hardware provided and tighten with an allen key. Centre of roof.

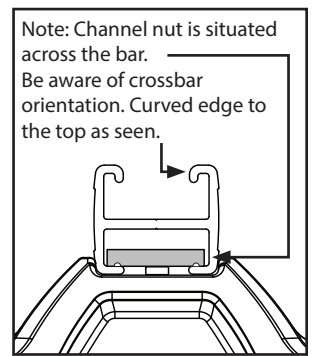
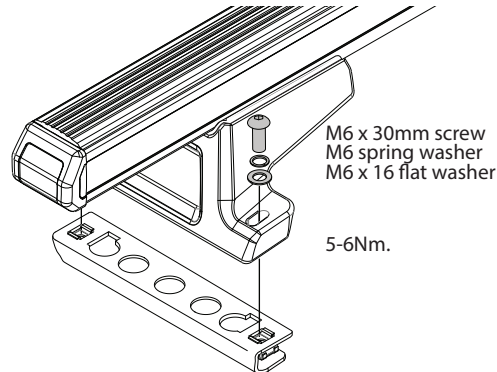

NOTE

ATTENTION:
Thoroughly check all fasteners are secure before driving away. Heights are for standard unloaded vehicles. Always check your specific vehicles height.

