

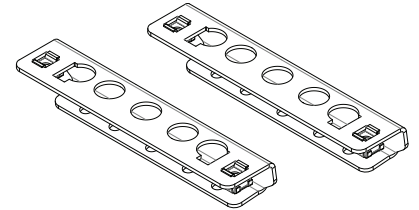

'Tradie Tuff' COMMERCIAL ROOF RACKS

MERCEDES VITO W447,
LOW ROOF 07/2015 - ON

FIXED MOUNT



PART NUMBER: VAS.RC1086, VAS.RA1086, VAS.RC1062, VAS.RA1062, VAS.RC1093, VAS.RA1093, VAS.RC1095, VAS.RA1095.

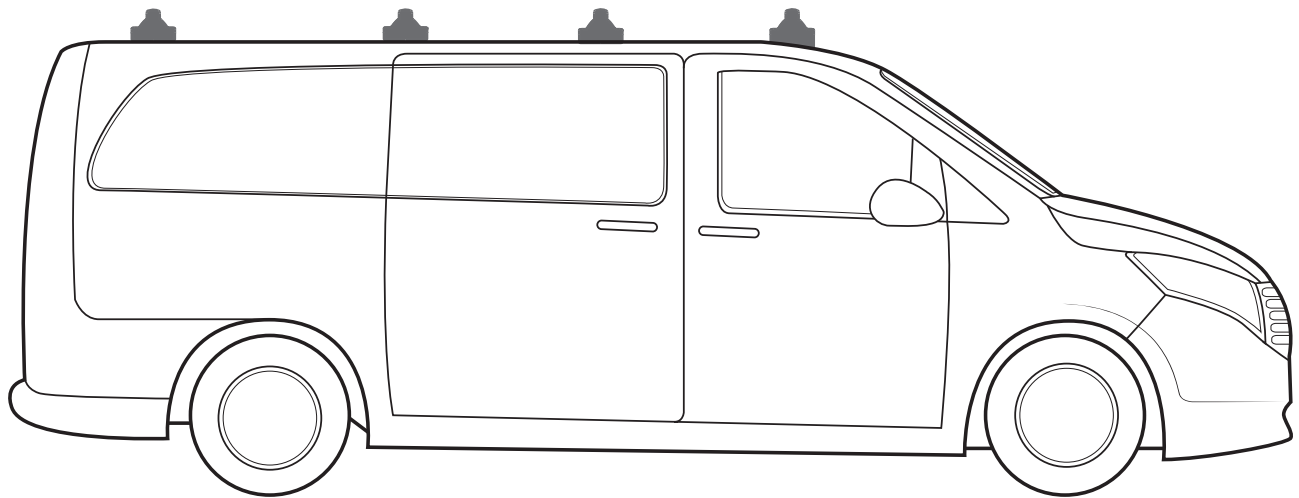

Note:

- PLEASE READ INSTRUCTIONS AND CHECK CONTENT PRIOR TO INSTALLING.
- PLACE INSTRUCTIONS IN VEHICLES GLOVE COMPARTMENT AFTER INSTALLING.



3 Bar maximum capacity: 100kg
 4 Bar maximum capacity: 100kg
 Tested to AS/NZS 1235-200 ADR standards

- Please check your vehicle's manual for vehicle load capacity (please do not exceed the lowest load rating) and please download and read our Load Rating guide which can be found on our website vas.com.au.
- Load rating is based on driving on sealed roads to road conditions and includes weight of roof rack system.

Important information

- Complete maintenance checks weekly including bolt connections and tightness.
- Heavy loads carried near feet
- Overhanging loads should conform to relevant state laws
- Check tie down strap tension every 50klm as loads can shift
- Specialised equipment carriers such as ladder slides should be used
- Ensure your roof racks, ladder rails and or load does not inhibit the tailgate lifting on vehicles manufactured with these doors
- Check car park heights before entering
- Keep load under the maximum capacity
- Use non stretch fastening straps
- Remove roof racks prior to using an automatic car wash

Note: The handling characteristics of a vehicle will change when a carrier system is fitted. Driving technique such as speed reduction, cornering techniques and braking distances should be altered to allow for these changes.

Kit Inclusions

Item	Part	3 Bar	4 Bar
1	M6 x 30mm Button Head Screw - F008	12	16
2	M6 Spring Washer - F012	24	32
3	M6 x 16mm Flat Washer - F011	24	32
4	M6 x 12mm Button Head screw - F004	12	16
5	Common Bracket - C087	6	6
6	Allen Tool - C028	1	1
7*	Front Mount C220L & C220R	2	2

* Sold separately in Front Mount Kit.

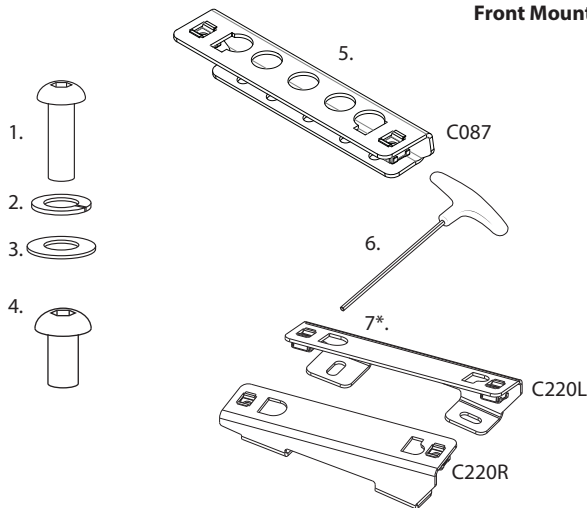

Tools Required

- 1 - Flat Blade Screw Driver.
- 2 - 4mm Allen Key (provided).
- 3 - Butyl Mastic.

Required kits (as separate):

- Crossbar x 4 1500mm
- 10mm Spacer x 2
- Crossbar Mount Kit x 4

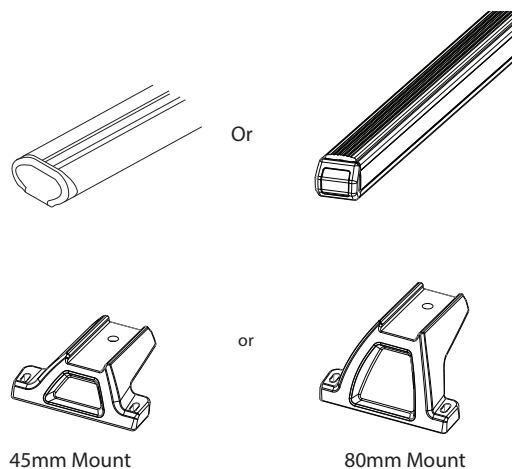

Step 1

Identify the plastic factory mounts on the roof of the vehicle. Using a screw driver, remove the threaded plugs from the mount points. Store in a safe place.

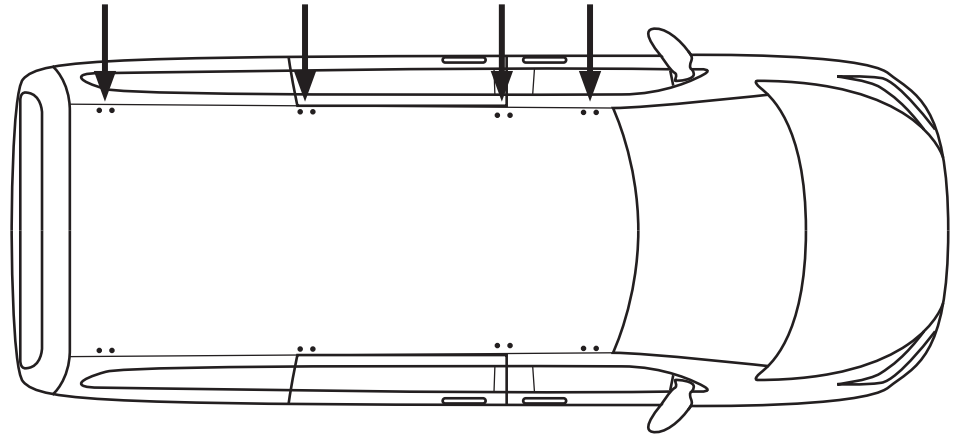
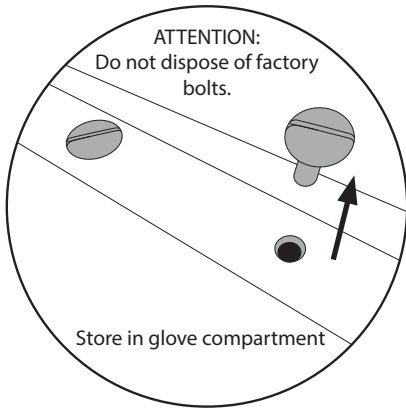

Step 2

Apply butyl mastic in and around the holes in the roof to ensure your roof remains water tight. A small amount inside the thread is advised.

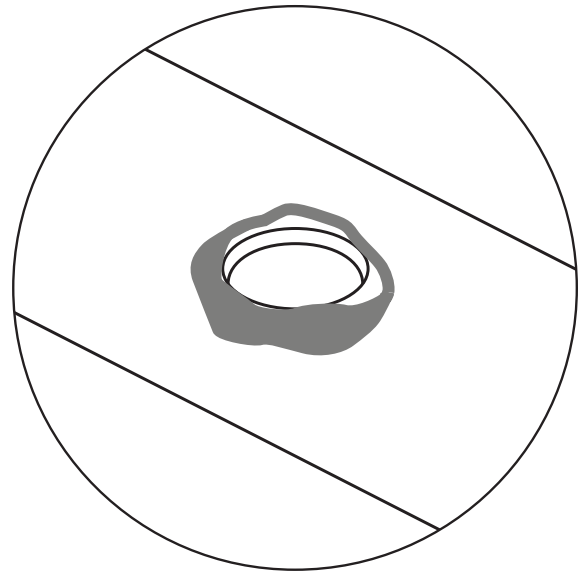
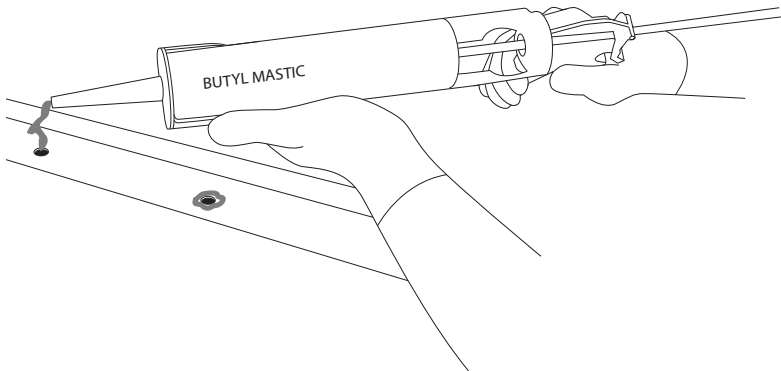

Step 3

1 - Install the M6 hardware into each bracket. 2 - Place the assemblies over the exposed mounting points in the roof. 3 - Tighten the middle and rear assemblies with the allen key provided. The front brackets will be tightened at a later stage.

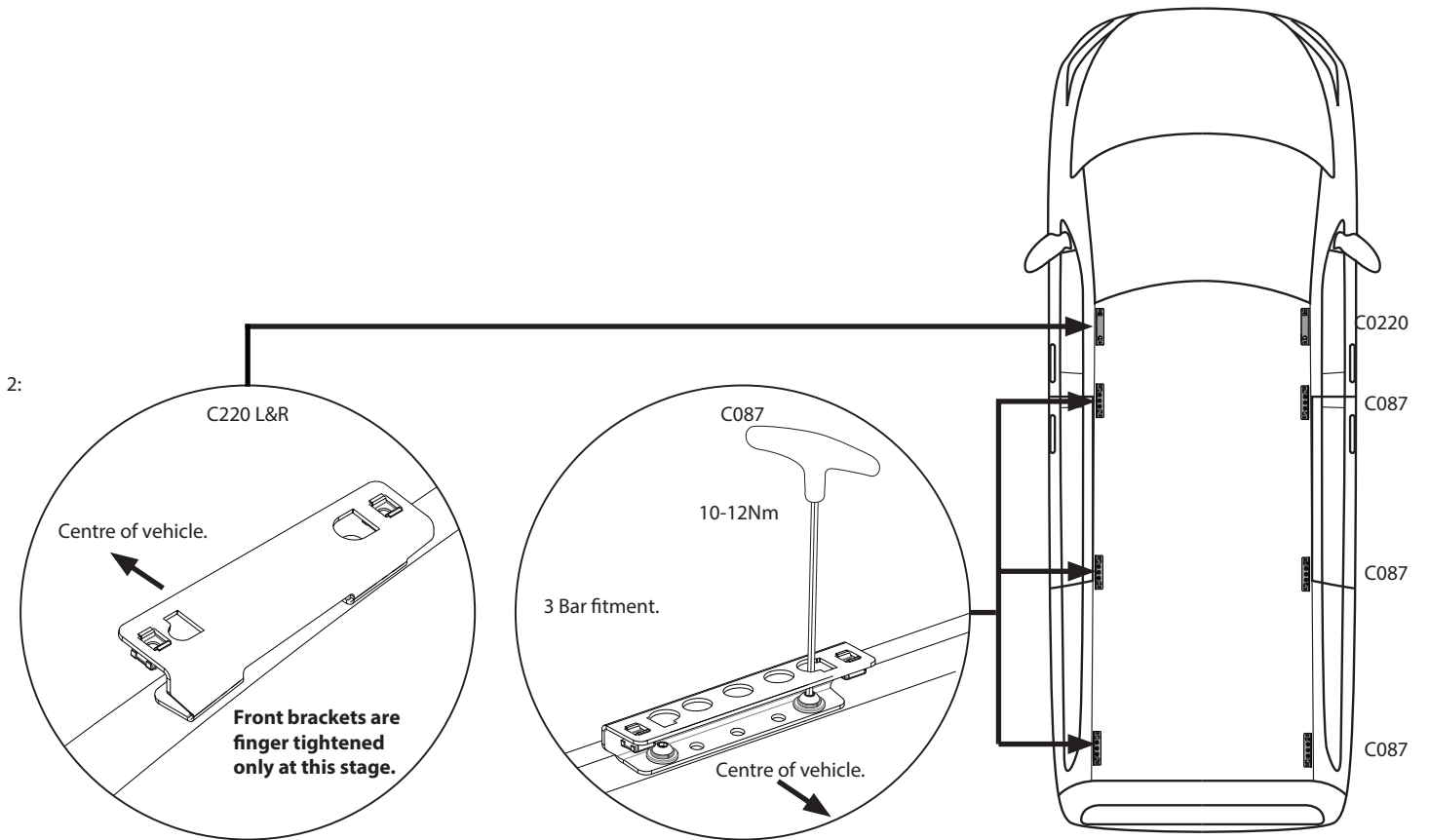
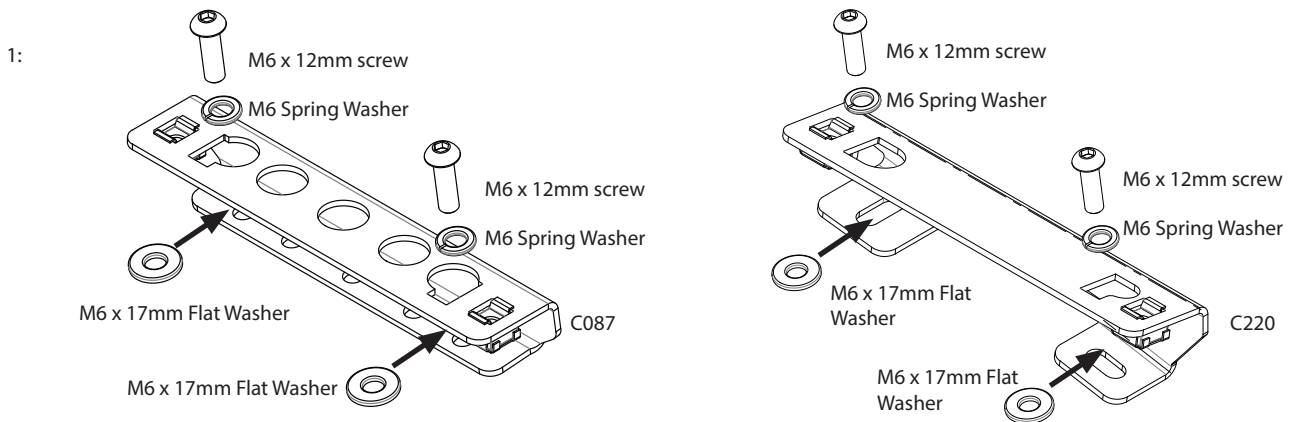

Step 4

Loosely attach a crossbar to the front installed brackets

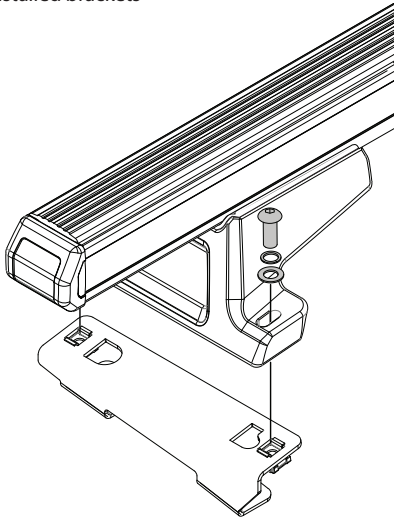

The crossbar will pull the brackets into line on the roof.

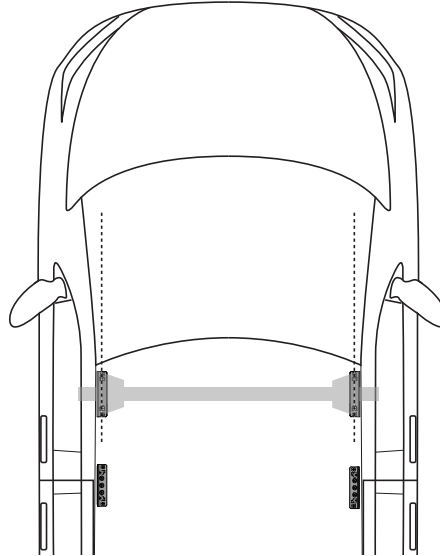

Now that the brackets are parallel, carefully remove the crossbar and tighten the brackets to the roof.

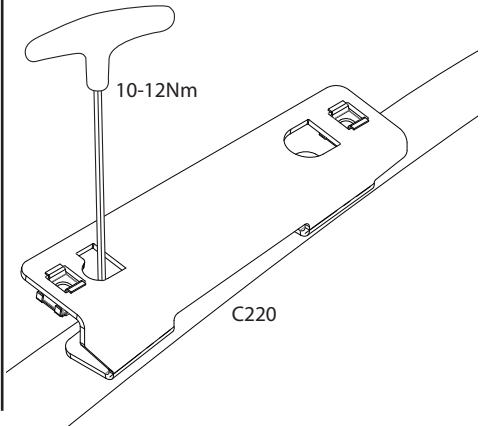

Step 5

Complete crossbar mount kits as specified in their instructions. Place the crossbars onto the installed brackets in the roof. Fix in place with the M6 hardware provided and tighten with an allen key. Note that the rear crossbar requires a 10mm spacer and standard high mounts.

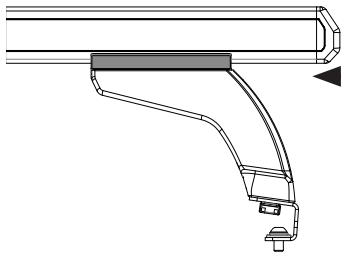

For rear crossbar only, install a 10mm spacer and standard high mounts.

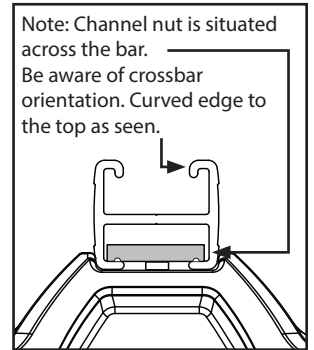
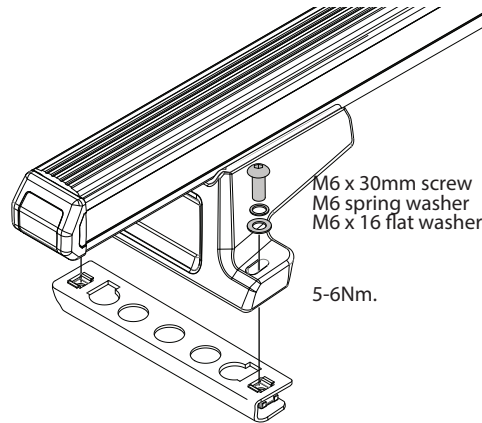

NOTE

ATTENTION:
Thoroughly check all fasteners are secure before driving away. Heights are for standard unloaded vehicles.
Always check your specific vehicles height.

4 Crossbar setup

